

SIAT

MAILLIS

SR46 Semi-Automatic Carton Sealers



Descent limiting device

Aluminium telescopic legs

Pneumatic centering unit

CE

for more details:



SR46

SR46 is a semi-automatic sealing machine with random adjustment. The machine consists of a metal structure painted with epossidic paint and columns in aluminium. The sliding plan of boxes is made up of galvanized rolls and stainless steel plate.

Working Cycle: the operator folds the top flaps and moves box forward in the machine until it is taken away by drive belts. The case sealer adjusts itself according to the box size and proceeds with the top and bottom sealing.

The machine has been designed in compliance with CE regulations.



other languages: www.siat.com



> Taping units
Unità nastranti
Verschliesseinheiten
Unités enrubanneuses
Unidades de precinto

> K12R
TOP VERSION



> K12R
BOTTOM VERSION



> Machine dimensions
Dimensioni macchina
Machinemessungen
Dimensions machine
Dimensiones de máquina

Size / Weighth packaging			LxWxH
> SR46	180	225	135x105x155

> SR46

	Min.	Max
L	1395	-
W	890	-
H	1560	1900
cbh	480	800
AS 77	cbh +110	cbh +110
AS 80	cbh +160	cbh +160

> SR46

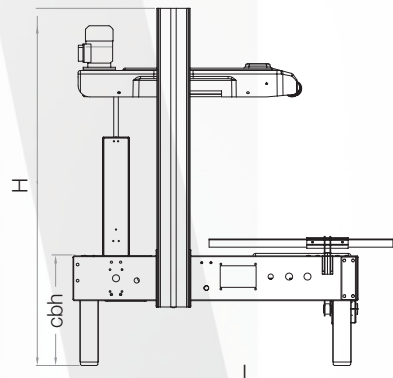

> Box dimensions
Dimensioni delle scatole
Kartonabmessungen
Dimensions des boîtes
Dimensiones de cajas

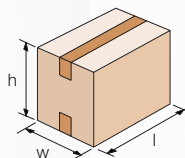

> SR46

	K12R	
	Min.	Max
l	150	∞
w	170	650
h	100	650

> Production capacity
Capacità di produzione
Produktionskapazität
Capacité de production
Capacidad de producción

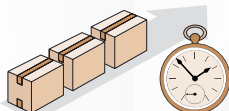

> SR46	Bph
Max pcs.*	900

* Always based on shorter manageable box

> Air consumption
Consumo aria
Druckluftverbrauch
Consommation air comprimé
Consumo de arie

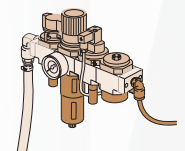

> SR46	NL.
Cycle	9

from 5,5 bar to 7 bar

> Standard voltage
Votaggio standard
Standardspannung
Tension standard
Voltaje estándar

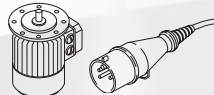

> SR46

380/400V - 50Hz - 3F	
440V - 60Hz - 3F	
Amps	1,08
Power kW	0,26
Phase	3Ph + N + PE

> Taping units
Unità nastranti
Verschliesseinheiten
Unités enrubanneuses
Unidades de precinto

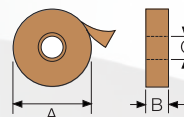

	K12R mm
A	410 Max
B	75
C	76

> Optionals
Accessori
Zubehör
Accessories
Accesorios

> AS80
Higher legs
Set gambe più alte
Höhere Stützen
Pieds plus hauts
Patas más altas

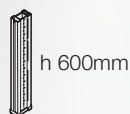

> AS77
Casters
Set ruote
Rädchen
Roulettes
Ruedas

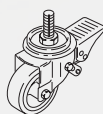

> RG
Roller conveyor
Piani a rulli
Rollenbahnen
Plans à rouleaux
Rodillos libres



> GTL - GTR
Extendable conveyor
Rulliera estensibile
Ausziehbare rollenbahnen
Convoyeur extensible
Rodillos extensibles

