





FORMATORI AUTOMATICI DI SCATOLE
 AUTOMATIC CASE ERECTOR
 FORMEUSE AUTOMATIQUE DES BOITES
 AUTOMATISCHER SCHACHTELAUFRICHTER
 FORMADOR AUTOMATICO DES CAJAS



 Esempio di linea di imballaggio completa di: Fomatore/Stazione di riempimento manuale/Sigillatura superiore della scatola/Rulliera estensibile in uscita.

 Example of packaging line, complete of: Case erector/manual filling station/Top box sealing/Exit extensible conveyor.

 Exemple de ligne d'emballage complète de: Formeuse de cartons/Station de remplissage manuelle/Enrubannage supérieure de la boîte/Convoyeur extensible à la sortie.

 Beispiel von vollständigen Verpackungslinie mit: Kartonaufrichter/ manuelle Füllungsstelle/ oberer Schachtelverschluss/ausziehbare Ausgangsrollenbahn.

 Ejemplo de línea de embalaje completa de: Fomador/Estación de llenado manual/Sellado superior de la caja/Dispositivo Rodillos extensible en salida.

Versioni - Versions - Modèles - Typen - Modelos

F144 / F145 / F146
 F344 / F345 / F346



- Formatore automatico Mod. F144 DX in versione Inox
- Automatic case erector, model F144 inox
- Formeuse automatique modèle F144 en acier inoxydable
- Automatischer Kartonaufrichter, Mod. F144 aus Edenstahl
- Formador automatico, modelo F144 en versión inoxidable



SIAT
 M. J. MAILLIS GROUP

Caratteristiche tecniche
 Specifications
 Caractéristiques techniques
 Technische Eigenschaften
 Características técnicas

Dimensioni delle scatole:
 Box dimensions:
 Dimensions boîte:
 Kartonabmessungen:
 Dimensiones de las cajas:

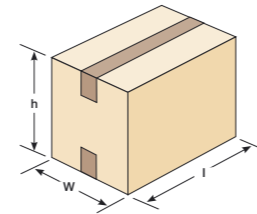

F144/4	MIN	MAX	F344/4	MIN	MAX
l	150	400	l	150	400
w	140	350	w	140	350
h	110	400	h	110	400

F144	MIN	MAX	F344	MIN	MAX
l	200	450	l	200	450
w	150	350	w	150	350
h	120	450	h	120	450

F145	MIN	MAX	F345	MIN	MAX
l	220	560	l	220	560
w	150	350	w	150	350
h	220	450	h	220	450

F146	MIN	MAX	F346	MIN	MAX
l	300	620	l	300	620
w	200	400	w	200	400
h	200	400	h	200	400

Produzione media:
 Average output:
 Production moyenne:
 Leistung:
 Producción media:

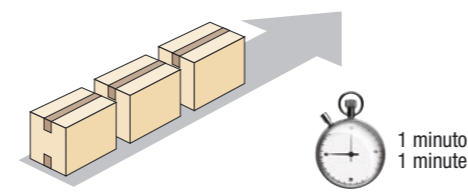

F144/4	12	F344/4	14 - 16 - 18
F144	10 - 12	F344	14 - 16 - 18
F145	8 - 10	F345	12 - 14 - 16
F146	6 - 8	F346	10 - 12 - 14

Consumo aria (lt./ciclo):
 Compressed air consumption (lt./cycle):
 Consommation air comprimé (lt./cycle):
 Druckluftverbrauch (Lt./Zyklus):
 Consumo de aire (lt./ciclo):

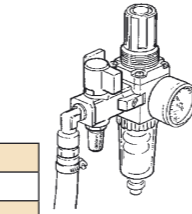

F144/4	22	F344/4	9
F144	22	F344	9
F145	25	F345	9
F146	30	F346	9

200 - 400 - 440	Trifase	220±240	Monofase
	3 Phase		Single phase
	tri-phasé		Mono-phasé
	3-phasing		1 phasing
	Trifásico		Monofásico



Come scegliere un formatore destro o sinistro quando si utilizzano scatole stampate.
 How to choose between a right hand and a left hand machine when using printed boxes.
 Comme choisir entre une formeuse droite ou gauche quand on travail avec bo tes imprimées.
 Wie eine rechte oder eine linke Maschine in hlen, we bedruckte Schachtel ben tzt werden.
 Como se escoge un formador derecho o izquierdo cuando se utilizan cajas impresas.

SIAT	DX	DESTRO	RIGHT	SIAT	SX	SINISTRO	LEFT
		RECHTS	RECHTS			GAUCHE	GAUCHE
		DERECHOS	DERECHOS			IZQUIERDOS	IZQUIERDOS

- Modifiche da apportare alle scatole quadrate
- Modifications to be done on the squared boxes
- Modifications à faire sur les boîtes carrées
- Änderungen, die auf den quadratischen Schachteln gemacht werden müssen
- Modificaciones de hacer sobre las cajas cuadradas

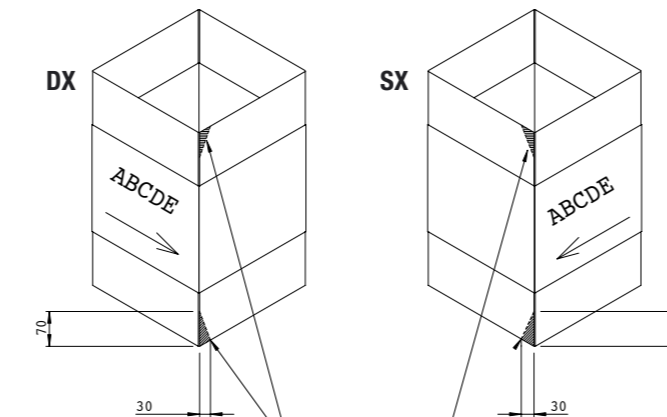

Spigoli da tagliare
 Edges to be cut
 Arêtes à couper
 Kanten, die geschritten werden müssen
 Esquinas de cortar

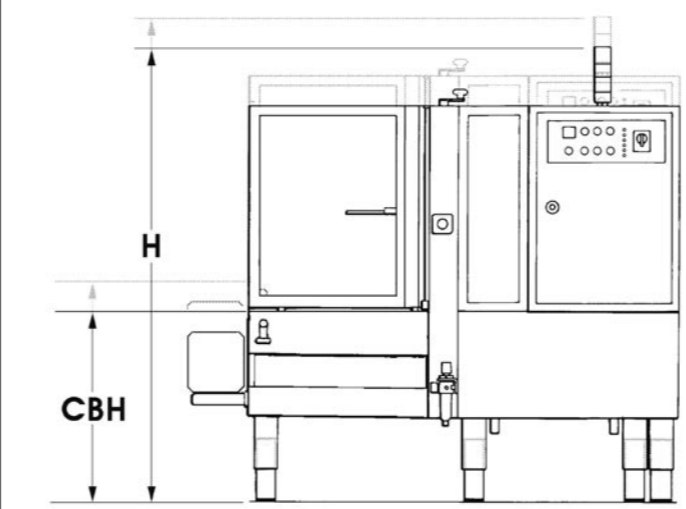

CBH	F144 / 344	MIN. 545 MAX 700
CBH	F145 / 345	MIN. 545 MAX 700
CBH	F146 / 346	MIN. 575 MAX 730

650 Kg

Cod.pubbli.:SBC0011521

SIAT
 M. J. MAILLIS GROUP

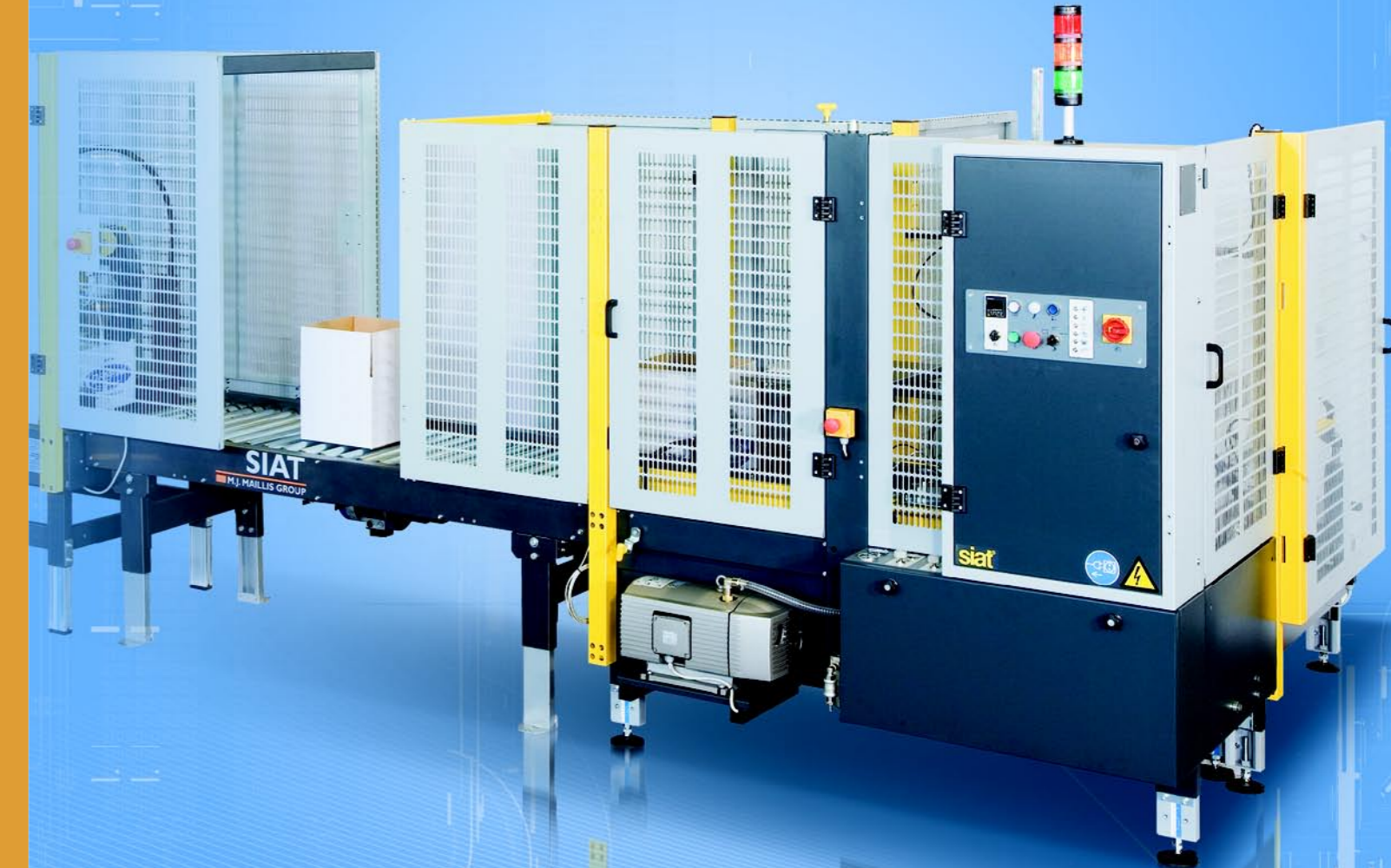

F144
F145
F146

F344
F345
F346

FORMATORI AUTOMATICI DI SCATOLE
 AUTOMATIC CASE ERECTORS
 FORMEUSES AUTOMATIQUES DES BOITES
 AUTOMATISCHE SCHACHTELAUFRICHTER
 FORMADORES AUTOMATICOS DES CAJAS

- Segnalatore luminoso a 3 posizioni
- 3 levels light
- Signaleur lumineux à 3 positions
- 3 Stellen leuchtender Signalgeber
- Indicador luminoso a 3 posiciones



- Pompa a vuoto per la presa delle scatole
- Vacuum pump for box keeping
- Pompe à vide pour la prise des boîtes
- Vakuumpumpe zum Schachtelhalten
- Bomba de vacío para el enganche de las cajas

F344-345-346

- Assi elettrici per una più rapida movimentazione e formatura della scatola
- Electric axis for a faster box moving and squaring
- Axes électriques pour déplacer et former la boîte plus rapidement
- Elektrische Achse zur schnelleren Bewegung und Formgebung der Schachtel
- Ejes eléctricos para un veloz el desplazamiento y la formación de las cajas

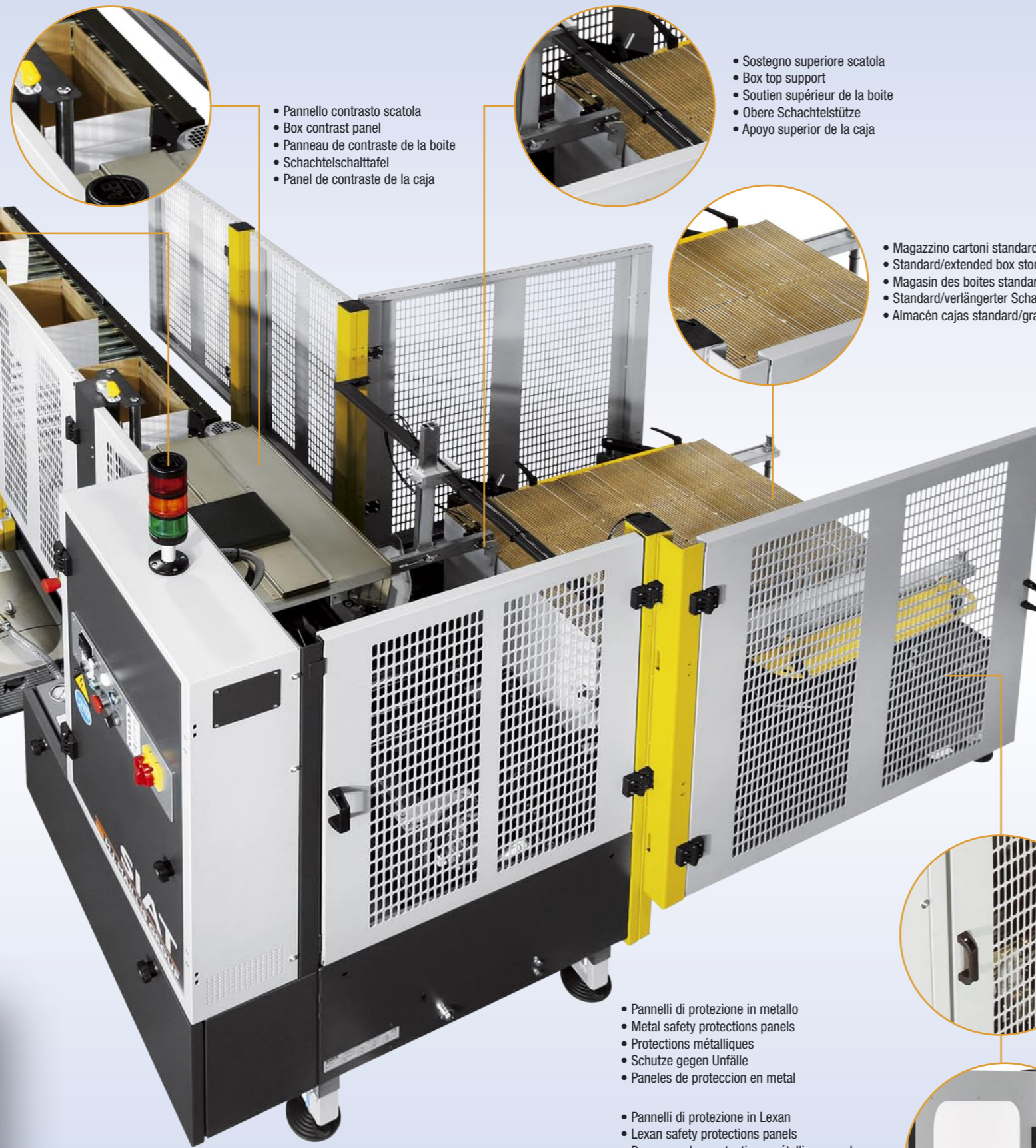

- Pannello contrasto scatola
- Box contrast panel
- Panneau de contraste de la boîte
- Schachtelschalttafel
- Panel de contraste de la caja

- Sostegno superiore scatola
- Box top support
- Soutien supérieur de la boîte
- Obere Schachtelstütze
- Apoyo superior de la caja

- Magazzino cartoni standard/prolungato
- Standard/extended box storage
- Magasin des boîtes standard/prolongé
- Standard/verlängerter Schachtellager
- Almacén cajas standard/grande

- Pannelli di protezione in metallo
- Metal safety protections panels
- Protections métalliques
- Schutze gegen Unfälle
- Paneles de protección en metal

- Pannelli di protezione in Lexan
- Lexan safety protections panels
- Panneaux des protections métalliques on Lexan
- Schutze aus Lexan gegen Unfälle
- Paneles de protección en Lexan

F344-345-346

- Pannello di controllo Touch-Screen per la gestione delle funzioni macchina
- Touch-Screen control panel for machine functions management
- Panneau de commande Touch-Screen pour la gestion des fonctions de la machine
- Digitale Schalttafel zur Führung der Maschinenbetriebe
- Panel de control Touch-Screen por la gestión de las funciones de la maquina



F144-145-146

- Pannello di controllo con indicatori ottici anomalie di funzionamento
- Control panel with optic indicators of operation anomalies
- Panneau de commande avec indicateurs optiques d'anomalies de fonctionnement
- Schalttafel mit Sichtmelder im Fall von Störungen
- Panel de control con indicador optico de los defectos de funcionamiento



F144-145-146

- Cilindri pneumatici per la movimentazione e la formatura della scatola
- Pneumatic cylinders for box moving and box squaring
- Pneumatiques pour déplacer et former la boîte
- Cylindres pneumatiques pour déplacer et former la boîte
- Pneumatische Zylinder zur Bewegung und Formgebung der Schachtel
- Cilindros neumáticos para el desplazamiento y la formación de las cajas

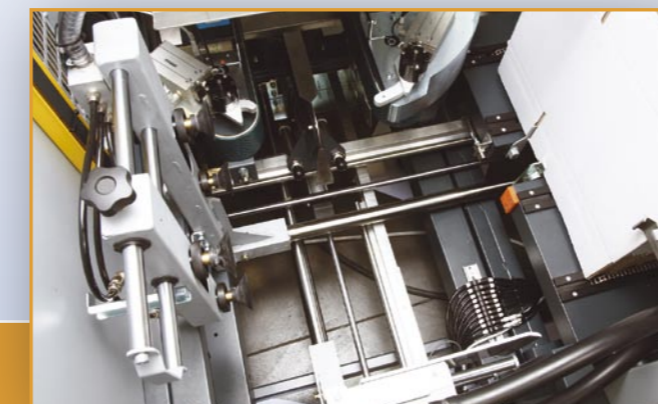

Caratteristiche tecniche / Specifications / Caractéristiques techniques / Technische Eigenschaften / Características técnicas

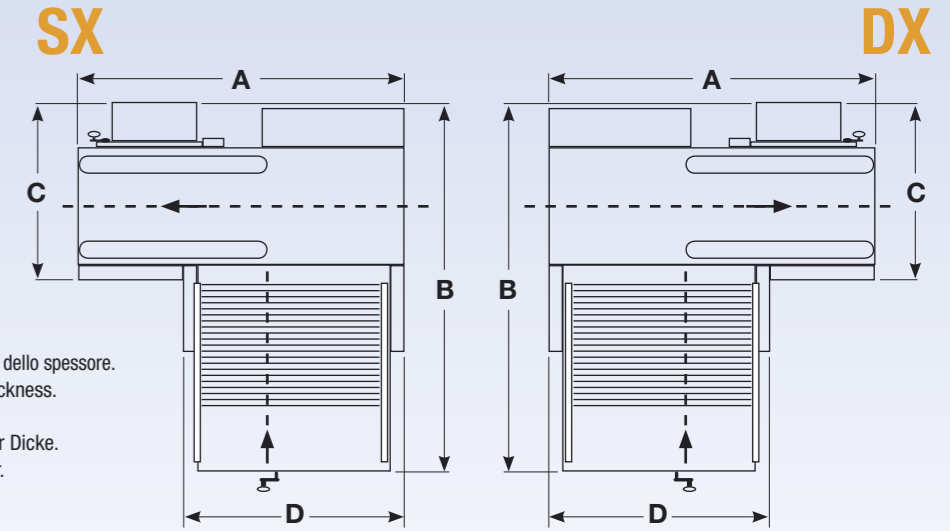

Magazzino cartoni standard: capacità 80 ÷ 150 scatole, in funzione dello spessore.
 Standard box storage capacity: 80 ÷ 150 boxes according to thickness.
 Capacité magasin standard: 80 ÷ 150 boîtes selon épaisseur.
 Standardleistung des Kartonlagers: 80 ÷ 150 Kartons gemäß der Dicke.
 Almacén cajas standard: 80 ÷ 150 cajas, en función del espesor.

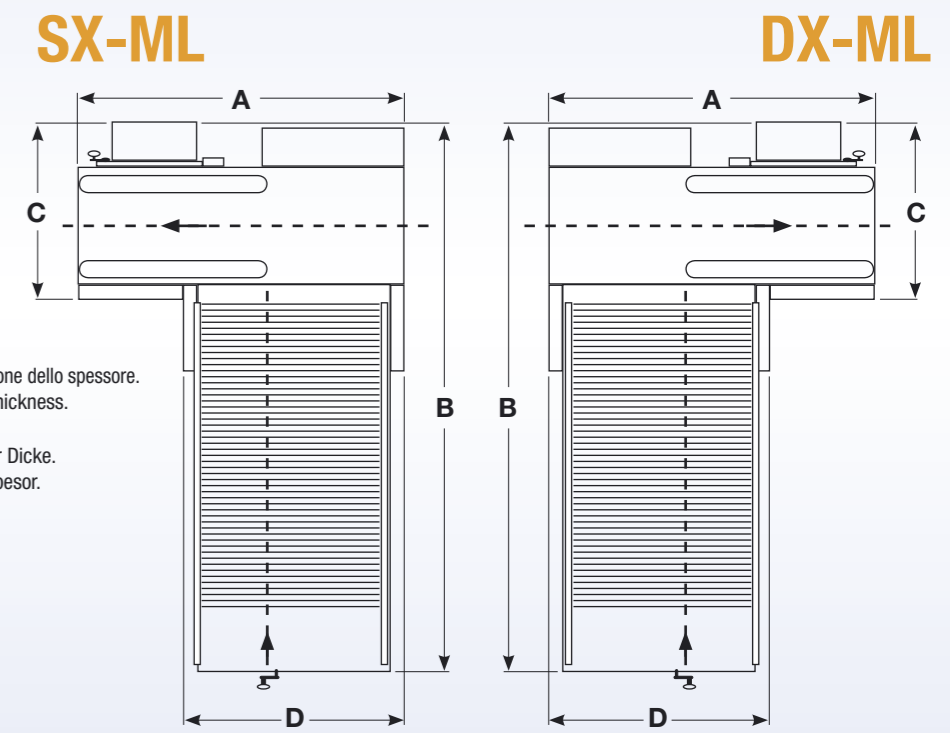

Magazzino cartoni prolungato: capacità 160 ÷ 300 scatole, in funzione dello spessore.
 Extended box storage capacity: 160 ÷ 300 boxes according to thickness.
 Capacité magasin prolongé: 160 ÷ 300 boîtes selon épaisseur.
 Leistung des verlängerten Lagers: 160 ÷ 300 Kartons gemäß der Dicke.
 Almacén grande para cajas: 160 ÷ 300 cajas, en función del espesor.

Dimensioni complessive con magazzino cartoni standard.
 Overall machine dimensions with standard box storage
 Dimensions machine avec magasin cartons standard
 Maschinenabmessungen mit standard Kartonlager
 Dimensión complessiva máquina con almacén cajas de cartón standard

	F144/4 F344/4	F144 F344	F145 F345	F146 F346
A	1720	1720	1840	1940
B	2280	2280	2300	2370
C	1060	1060	1020	1050
D	1100	1100	1230	1320
h	1700	1700	1800	1800

Dimensioni complessive con magazzino cartoni prolungato opzionale
 Overall machine dimensions with optional extended box storage
 Dimensions machine avec magasin cartons prolongé
 Maschinenabmessungen mit verlängertem Kartonlager
 Dimensión complessiva máquina con almacén cajas de cartón grande

	F144/4 F344/4	F144 F344	F145 F345	F146 F346
A	-	-	1840	1940
B	-	-	3340	3370
C	-	-	1020	1050
D	-	-	1220	1320
h	-	-	-	-